

Parts List			
ITEM	QTY	PART NUMBER	DESCRIPTION
1	2	339-6112-00	Can-Am Roof Light Bar Tab
2	8	339-6113-00	Can-Am Roof Bracket
3	13	013-8049-00	5/16-18 Nylon Flange Nut
4	13	018-8065-00	5/16" x 1" Carriage Bolt
5	4	318-1001-00	3_16_Aluminum Black Rivet
6	1	379-2008-00	Can-Am Rear Roof Weldment
7	1	379-2011-00	Can-Am Front Roof Weldment
8	1		14" Light Bar
9	2	Side Seal_1120A79	
10	1		Front Seal_24175K21
11	2		1/4-20 x 2" Carriage Bolt
12	1		14" light bar molding
13	2	M6x1x10 hex head	
14	2	013-2050-00	1/4-20 Nylon Insert flange Nut
15	4	ANSI B18.3.4M - M8 x 1.25 x 20	Forged Hexagon Socket Button Head Cap Screw - Metric
16	4	AS 1237 - 8	Flat metal washers for general engineering purposes (metric series)

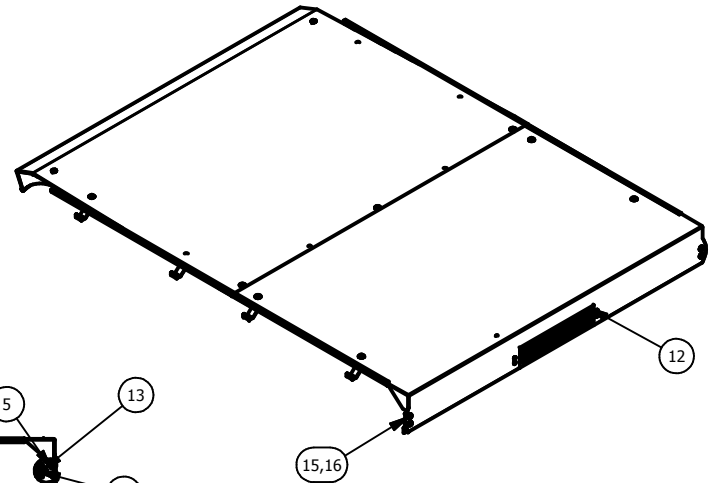

UNLESS OTHERWISE SPECIFIED:  
 ALL DIMENSIONS IN INCHES  
 DEBURR ALL SHARP EDGES  
 NOT TO SCALE  
 PART IS FULLY DESCRIBED  
 BY CAD MODEL

TOLERANCES:  
 .XX = ± .03  
 .XXX = ± .005  
 .XXXX = ± .0005  
 ANGULAR = ± 1°

Material:  
 Coating:

INFORMATION CONTAINED  
 IN THIS DRAWING IS THE  
 PROPERTY OF BAD BOY INC.  
 TRANSMISSION OF THIS  
 PRINT (WHOLE OR IN PART)  
 BY ANY MEANS  
 (ELECTRONIC, PHOTOCOPY,  
 OR OTHERWISE) TO A  
 THIRD, OUTSIDE PARTY IS  
 PROHIBITED WITHOUT THE  
 EXPRESS CONSENT OF BAD  
 BOY INC.



BAD BOY INC.  
 102 INDUSTRIAL DRIVE  
 BATESVILLE, ARKANSAS  
 72501

SCALE

PART NUMBER

388-2315-00

SHEET NUMBER

1 OF 1

DESCRIPTION  
 CAN-AM ROOF ASSEMBLY

FILE NAME

C:\VAULT\_LOCAL\BBM\ENGINEERING\PROJECTS\ZACHARY\TRUCK ACCESSORIES\CAN-AM\ROOF\ROOF ASSEMBLY.DWG

REV	DESCRIPTION	DATE	APPROVED
B	Updated Assembly for new design	6-21-17	ZWC
A	RELEASE		